

Another RF Signal Source: the "8640-Jr"

Wes Hayward, w7zoi, 26feb12, update 28/29Mar12, 9apr12.

Radio Frequency signal sources are like power supplies: we can always use one more of them. This signal source is based upon the Hewlett-Packard HP-8640B, which is one of the most popular generators available. The generator is no longer available new, having been replaced by more up to date synthesized instruments. But the 8640 is still available and popular on the surplus market. The HP-8640 uses a single variable oscillator operating at VHF. That source is then frequency divided to generate the various bands. The phase noise and stability get better as the division ratio increases. This divider chain basis is used in our design, although with significant simplification.

This signal source consists of a Hartley oscillator operating from 13.6 to 32 MHz. It is necessary to have a tuning range of at least one octave to really take full advantage of this divider topology. This range is available directly, or is divided by 2 or 4, providing output all the way down to 3.4 MHz. Each of the two divided ranges is filtered with a 5th order low pass filter. Only one such filter was used for each band. Each was designed for a cutoff frequency just above the top of the range. The passband ripple was varied to achieve convenient, off the shelf capacitor values in the filters. The harmonic suppression is reasonable, but is much worse than the instrument's namesake. The original HP-8640B has a stellar harmonic suppression of over 60 dB, which resulted from the use of 3 filters for each octave. The excellent suppression is atypically good for a signal generator. Our 8640-Jr signal source is shown in the schematic of Fig 1.

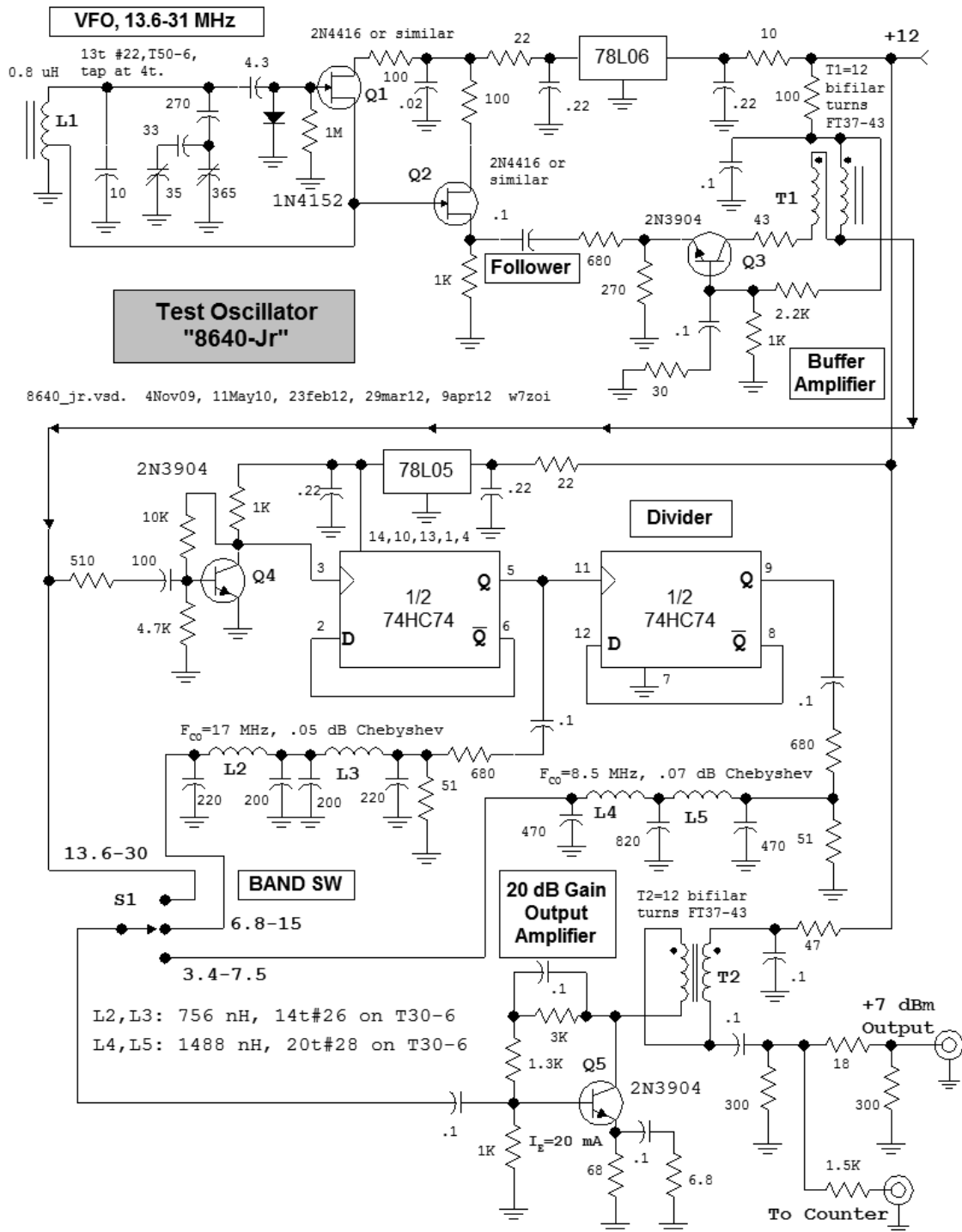

Fig 1. Schematic for the signal source. (Note that this schematic was updated on March 29th to include two resistors [30 and 43 Ohm] that were missing in the common base buffer, Q3. They are probably NOT necessary.)

Note that we don't call this a *signal generator*. A signal generator is a well shielded instrument that can be used to measure the sensitivity (MDS) of a serious

communications receiver, yet has enough output power to allow measurement with detectors of only modest sensitivity such as oscilloscopes. Not only is shielding good, but a signal generator is immune to interactions from other generators that might be attached. A modern signal generator has a well defined, low output impedance, usually 50 Ohms. Frequency stability is, of course, good. Our little offering does not fit all of these criterion. It is, however, reasonably stable. Moreover, the oscillator is well isolated from external influences, allowing it to be used with another similar unit for the evaluation of IMD of mixers or amplifier in the lab.

Photos of the rf source are shown below.



Fig 2. The upper gray box is an exterior view of the 8640-Jr. The lower box with three knobs is the RF source of fig 7.27, p 7.15 of [Experimental Methods in RF Design](#) (ARRL, 2003.)

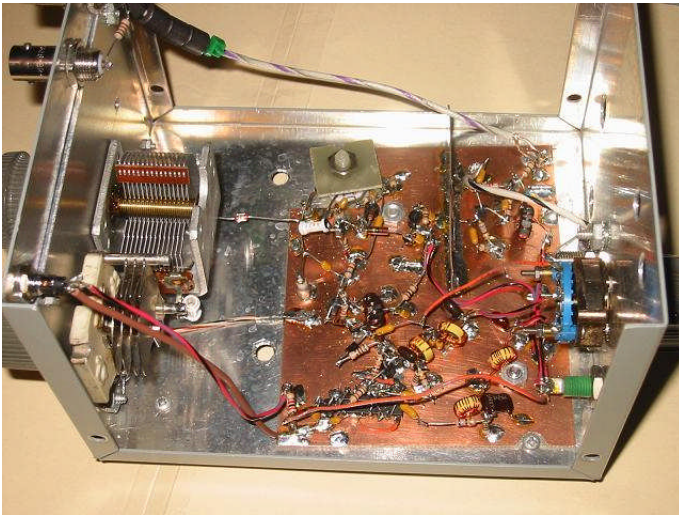

Fig 3. Inside view of the signal source, *ugly* to the core. The band switch is on the rear panel, something of an operational difficulty, although one easily fixed.

Examination of Fig 1 and of Fig 7.27 of EMRFD will show considerable similarity. In spite of this, this experiment provided a few interesting details which we will outline here.

The signal is extracted from the VFO with a source follower while it was pulled from the EMRFD signal source with a single turn link through the tank coil. The link is the preferred method, for the harmonic output is lower by over 20 dB. While the output amplifier contributes some of the harmonic distortion, the dominant contributor is the follower.

The secret of this design, although it is certainly not a secret, is the common base buffer. This was originally inserted in the EMRFD RF source when we tried to use the instrument to examine a crystal filter. The VFO would try to lock to the crystals when the output was reflected from the crystal filter and back through the output stage to the VFO. The extra buffer with its excellent reverse isolation completely eliminated this difficulty. The rf source had not been usable for IMD measurements until the common base buffer was added.

The VFO in the 'Jr originally used a 2.2 pF gate capacitor. The particular JFET we were using and perhaps the gate diode combine to compromise the starting gain for the oscillator. The circuit would change output level when at the lower end of the tuning range. The changes were often in the form of sharp steps in output level as frequency was changed. Changing the gate capacitor from 2.2 to 4.3 pF completely eliminated this problem.

Note the method of extracting signals from the divider chips. In each case, a large capacitor provides DC blocking so the following resistors do not alter the DC conditions on the CMOS chip. A voltage divider then drops the level to that needed to drive the output amplifier. The 680 Ohm resistor provides a high Z load that the divider can drive while the 51 Ohm resistor provides the proper resistance to terminate the low pass filter.

When first built, the 8640-Jr used a classic surplus variable capacitor from a WW-II BC434 Command Receiver. These feature a built in gear reduction drive (about 60:1) and a dial mechanism, all in a package that is surprisingly easy to mount and use. But there seemed to be problems with excess noise as the circuit was tuned. The capacitor was changed to another from the junk box, but the same problems were there.

Eventually, they were traced to the inadequate starting gain mentioned above. But this had not been confirmed until the capacitor had been swapped out for the 365 pF AM broadcast band capacitor. The combination of two capacitors works well, although the band spread is extreme at the low end of the tuning range while almost inadequate at the high end.

It was recently (28Mar12) brought to my attention that an enterprising purveyor of radio kits has decided to assemble a sack of parts for this design and offer it to the amateur radio community. He says that he will use *polyvaricon* variable capacitors instead of

the air variables that I used. This could lead to problems. See my Q measurement results on these parts at <http://w7zoi.net/2faces/twofaces.html>.

This design uses an output amplifier biased to about 20 mA emitter current. The similar stage in the EMRFD circuit, Fig. 7.27 had a current of 35 mA. This means that the output stage of the EMRFD circuit could be driven harder. This means that either the output could be higher, or that a larger output pad could be employed. Both would be an advantage.

There is no adjustment of output level. Some sort of variable attenuator would be handy such as the pot adjusted circuit of Fig. 7.22. Alternatively, a PIN diode attenuator would do the job.

Spectral analysis of the output is interesting. The harmonic attenuation is poor as mentioned above and depends upon the band selected as well as the position within the band. The high band, even when neither digitally derived output is in use, still has a spur at half the output frequency, but it is at about -55 dBc. This is some of the digitally derived lower frequency leaking through. Experimentation and design refinement would probably improve this problem.

The schematic diagram is labeled with an output power of +7 dBm. This is approximate. The following data was measured, showing a slight variation from the nominal value:

High band	+9.2 dBm at 13.6 MHz	+7.6 dBm at 32.6 MHz
Mid band	+4.8 dBm at 16.3 MHz	+8.0 dBm at 6.8 MHz
Low band	+6.8 dBm at 8.17 MHz	+8.2 dBm at 3.4 MHz

The low pass filters are purposefully designed for a cutoff that is close to the top of the respective bands. Hence, it is important to actually measure the inductance and capacitance value, or otherwise confirm the proper operation of these filters. If the filters are suspect, they can be bypassed during construction and debugging.